

RieVo BV *Handelsonderneming*



AGILE

THE MOST COMPACT EXPRESSION OF POWER

THE SMALLEST, FASTEST & STRONGEST FORKLIFT OF THE POULTRY INDUSTRY

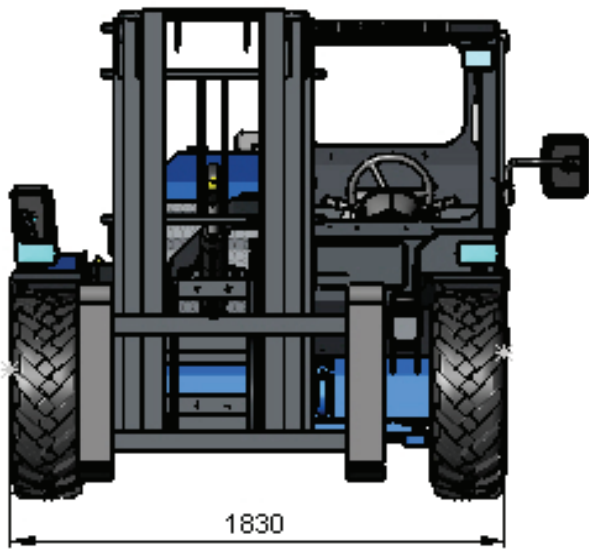

Compact&Agile

Only 1,6 meters high and 3,30 meters long, this compact machine is perfect in low and multi-floor houses.

The special back wheel steering with a turning radius of 3,3 meter, helps the AGILE to turn in narrow spaces.

Fast&Powerful

The powerful Perkins engine allows the AGILE to go up to 27 Km/H.

User friendly

With only a few commands the driver can operate easily and with precision. The side mounted cabin is easy to enter, for quick access in and out.

Version

Depending on your wishes the forklift can be mounted with a Closed or Open cabin, protecting the driver. The Closed cabin can be equipped with heating and air conditioning.

Air Filter

Since the AGILE is born for the poultry field, it is equipped with a triple air filter for protecting the engine.

Optional

The optional Side-shift can help to make the job easier and faster. The standard hydraulic sockets allows other equipment to be used in combination with the forklift, such as the RIEVO Sweeper, for cleaning the houses.

Counterweight

The counterweight on the back of helps the Forklift to be stable when working with double containers.

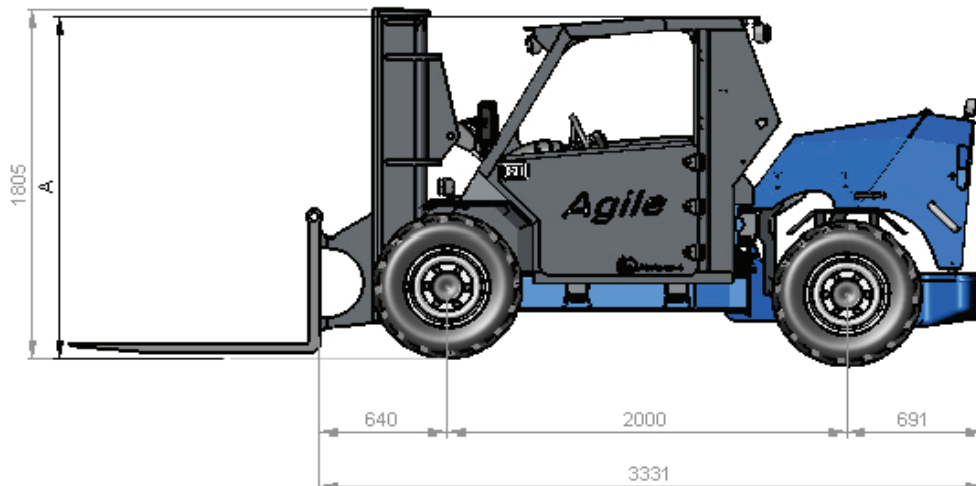

“A” DEPENDS ON DIFFERENT TYPE OF CABIN

TYPE OF CABIN	HIGH
Low cabin	1650 mm
High cabin	1800 mm

PERFORMANCE

Maximum load	2000 KG / 4410 LB
Maximum height	Changeable
Fork rotation angle	+10° / -10°
Tearing force	2.400 DaN
Total empty weight	3700 KG
Speed	27 Km/H

TRANSMISSION

Hydrostatic transmission with variable displacement
4 hydraulic motors
2 hydraulic pedals for forwards and backwards movement
Handbrake by electric switch

ENGINE

 Perkins	803 D
Maximum net power	47 Kw / 64 HP
Type	4 stroke
Cylinders	4 in vertical line
Displacement	3.300 cc
Cooling	Liquid
Max. Rpm	2600

CAPACITY

Hydraulic oil tank	120 Lt
Fuel tank	75 Lt

PNEUMATICS

Front/Back	10.0 / 75 – 15,3
------------	------------------

STANDARD FEATURES

Hydraulic socket for attachments
Self clearing cyclone filter

OPTIONAL FEATURES

Closed cab
Heater
Air conditioning
Side-shift
Rotator

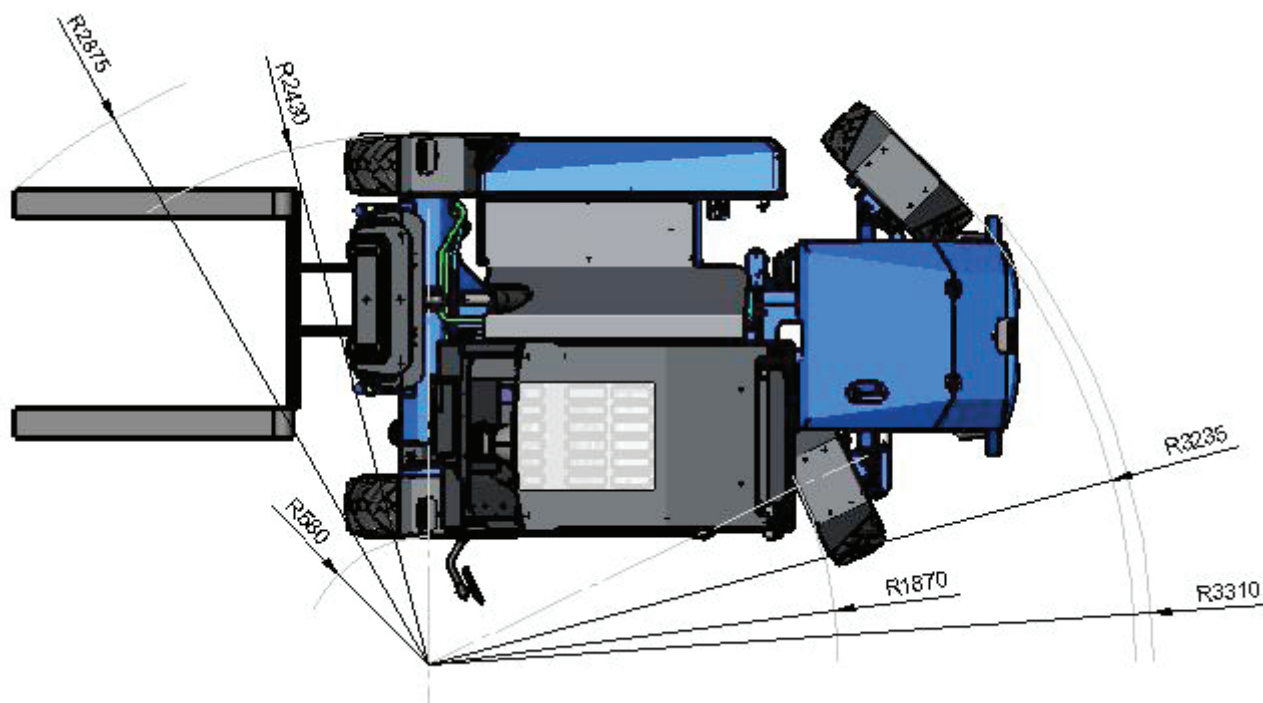

 **RieVo BV**
Handelsonderneming

Rievo Handelsonderneming | Blokenstraat 12a | 4885 JH Achtmaal
T +31 (0)76 598 51 47 | F +31 (0)76 598 52 25 | E info@rievo.nl

Version 1.6: 21.09.2011

WWW.RIEVO.NL